

PROJECT NO.	YEAR	SHEET NO.
XXXXXX	2025	1

REVISIONS			
NO.	DATE	BY	BRIEF DESCRIPTION

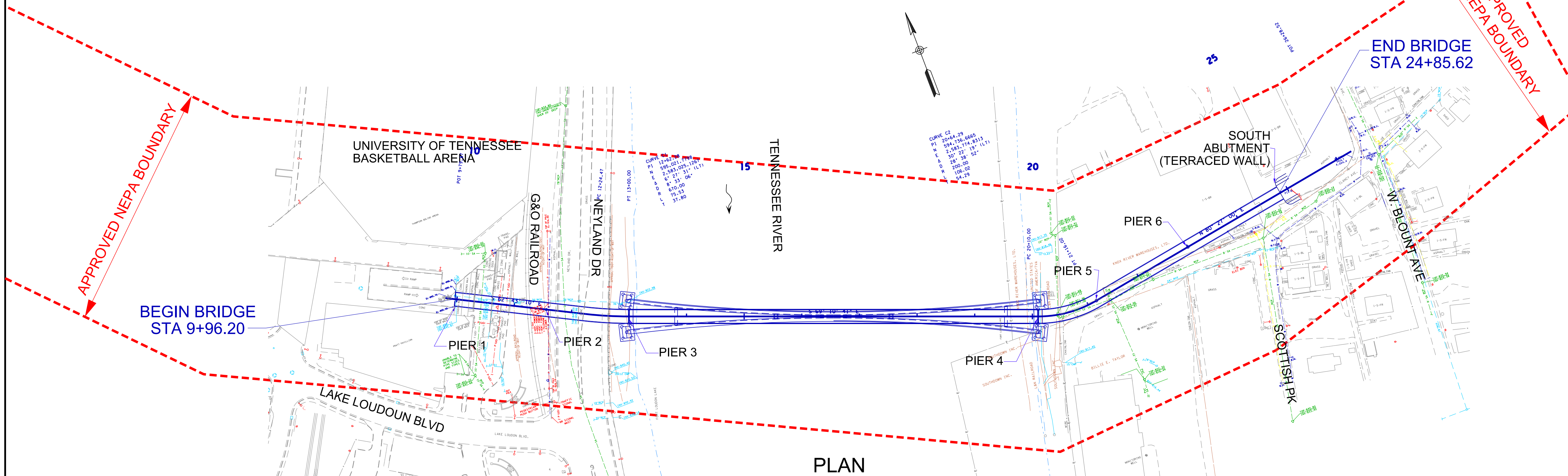

**PRELIMINARY
BRIDGE PLAN**

**CAUTION!
PRELIMINARY
PLANS
SUBJECT TO
CHANGE**

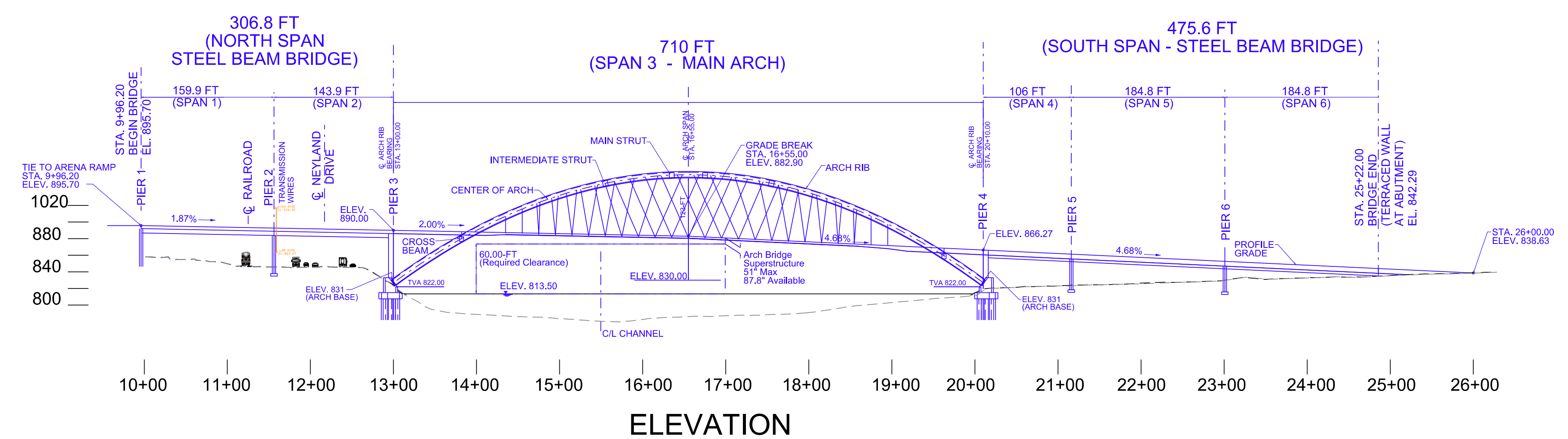

SEALED BY

10/28/2025 7:00:59 PM C:\WSA_PROJECTS\Knoxville\Waterfront_Ped_Bridge_Design-2023\2025 - DISPLAY.dgn



PIN NO.		
DESIGNED BY	FB	DATE OCT 2025
DRAWN BY	DP	DATE OCT 2025
SUPERVISED BY	FB	DATE OCT 2025
CHECKED BY	JM	DATE OCT 2025

SCALE: 1"=100'

CITY OF KNOXVILLE
URBAN DESIGN & DEVELOPMENT / ENGINEERING
SOUTH WATERFRONT PEDESTRIAN BRIDGE OVER TENNESSEE RIVER
KNOX COUNTY
2025

PROJECT NO.	YEAR	SHEET NO.	
XXXXXX	2025	1	
REVISIONS			
NO.	DATE	BY	BRIEF DESCRIPTION

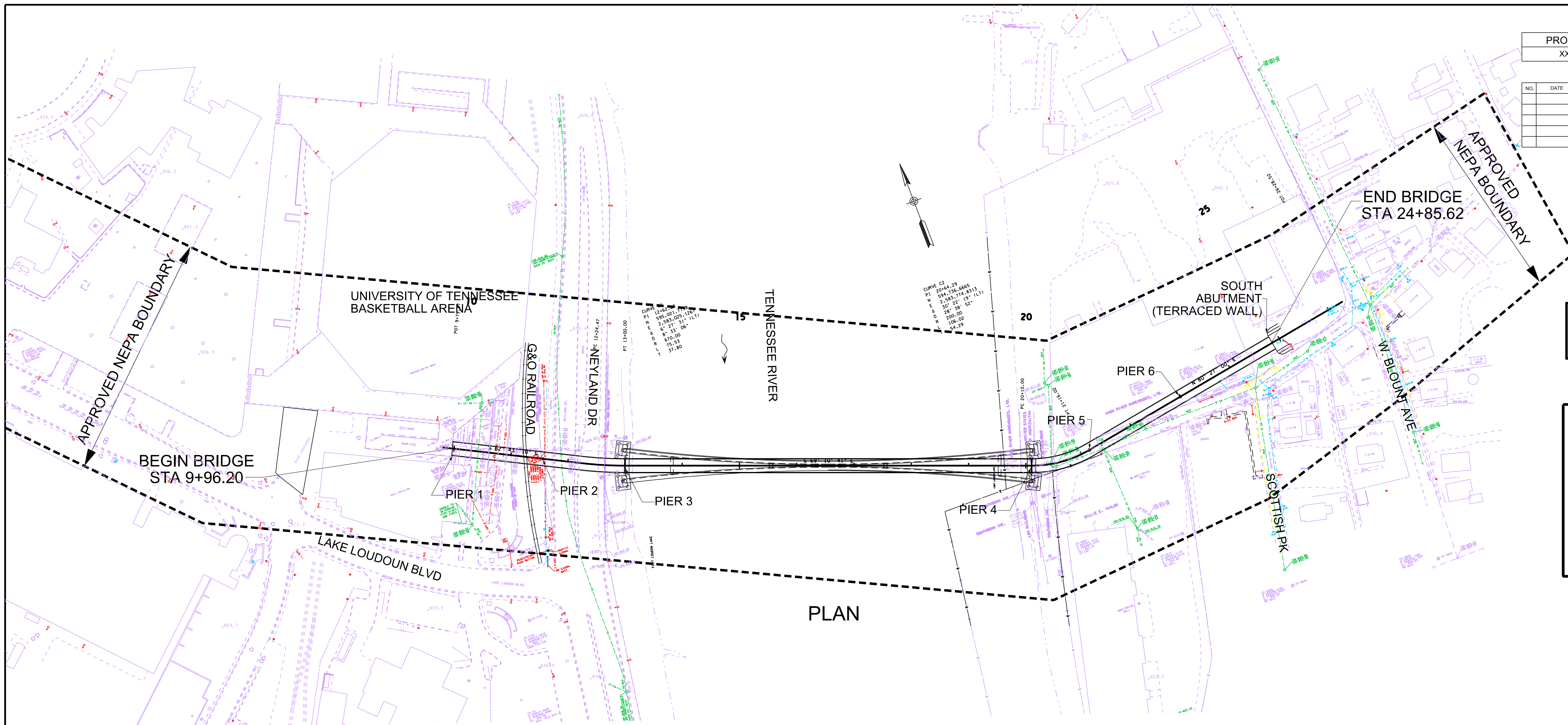

EXISTING UTILITY
RAINBOW PLAN

CAUTION!
PRELIMINARY
PLANS
SUBJECT TO
CHANGE

PLAN

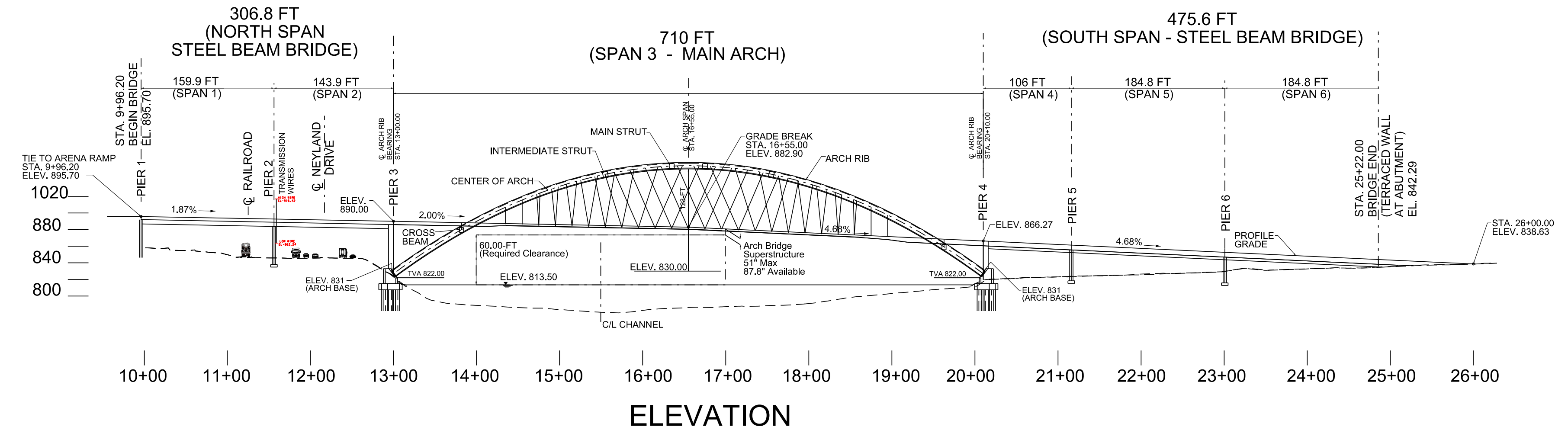

ELEVATION

SCALE: 1"=100'

SEALED BY

CITY OF KNOXVILLE
URBAN DESIGN & DEVELOPMENT / ENGINEERING
SOUTH WATERFRONT PEDESTRIAN BRIDGE OVER TENNESSEE RIVER
KNOX COUNTY
2025



PIN NO.	DESIGNED BY	DATE
	FB	OCT 2025
DRAWN BY	DP	OCT 2025
SUPERVISED BY	FB	OCT 2025
CHECKED BY	JM	OCT 2025

12/8/2025 14:55:54 PM C:\WSA_PROJECTS\Knoxville\Waterfront\Ped.Bridge-Design\2025\Knoxville Ped Bridge Prelim.dgn

CONST. NO.:

PROJECT NO.	YEAR	SHEET NO.
XXXXXX-MX-XXX	2025	2

REVISIONS

NO.	DATE	BY	BRIEF DESCRIPTION

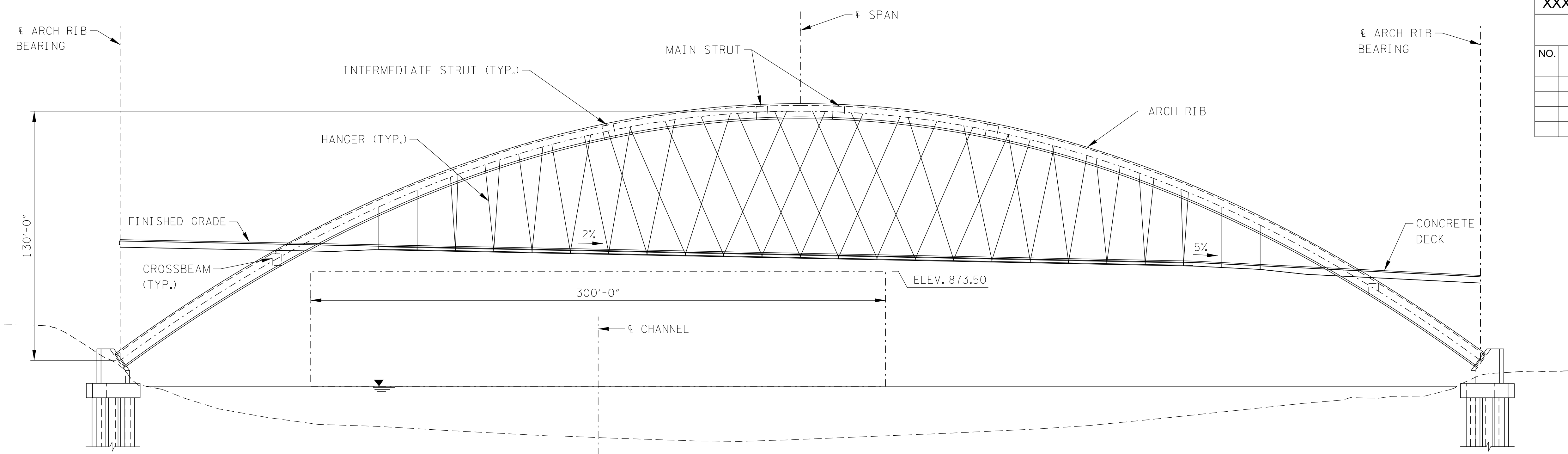

ELEVATION
SCALE: 1' = 380'-0"

CAUTION!
PRELIMINARY
PLANS
SUBJECT TO
CHANGE

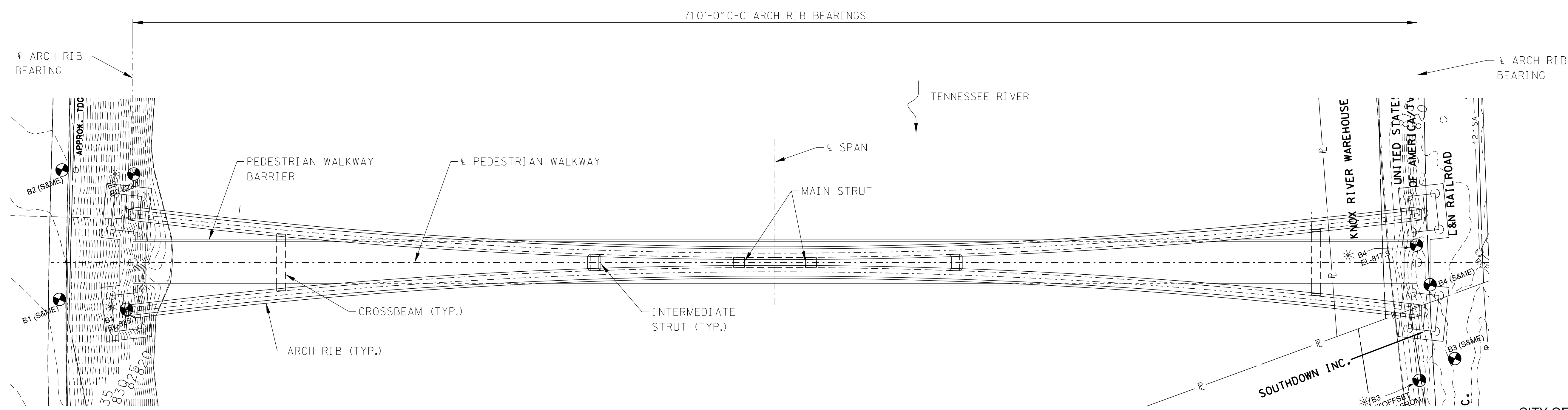
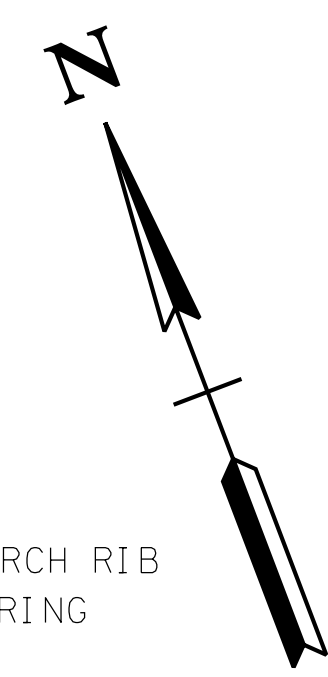

PLAN
SCALE: 1' = 380'-0"

SEALED BY

CITY OF KNOXVILLE
URBAN DESIGN & DEVELOPMENT / ENGINEERING
SOUTH WATERFRONT PEDESTRIAN BRIDGE OVER TENNESSEE RIVER
KNOX COUNTY
2025

PIN NO.:
 DESIGN BY: ARA DATE: FEB 2024
 DRAWN BY: DJC DATE: FEB 2024
 SUPERVISED BY: DEM DATE: FEB 2024
 CHECKED BY: DATE:



2/6/2024 10:18:37 AM
\\MDC\01\Projects_214733\01-Knoxville Pedestrian Bridge\CADD\Structural\4773.01-XX-Arch Bridge Plan & Elev.dgn

CONST. NO.:

PROJECT NO.	YEAR	SHEET NO.
XXXXXX-MX-XXX	2025	3

REVISIONS			
NO.	DATE	BY	BRIEF DESCRIPTION

CAUTION!
PRELIMINARY
PLANS
SUBJECT TO
CHANGE

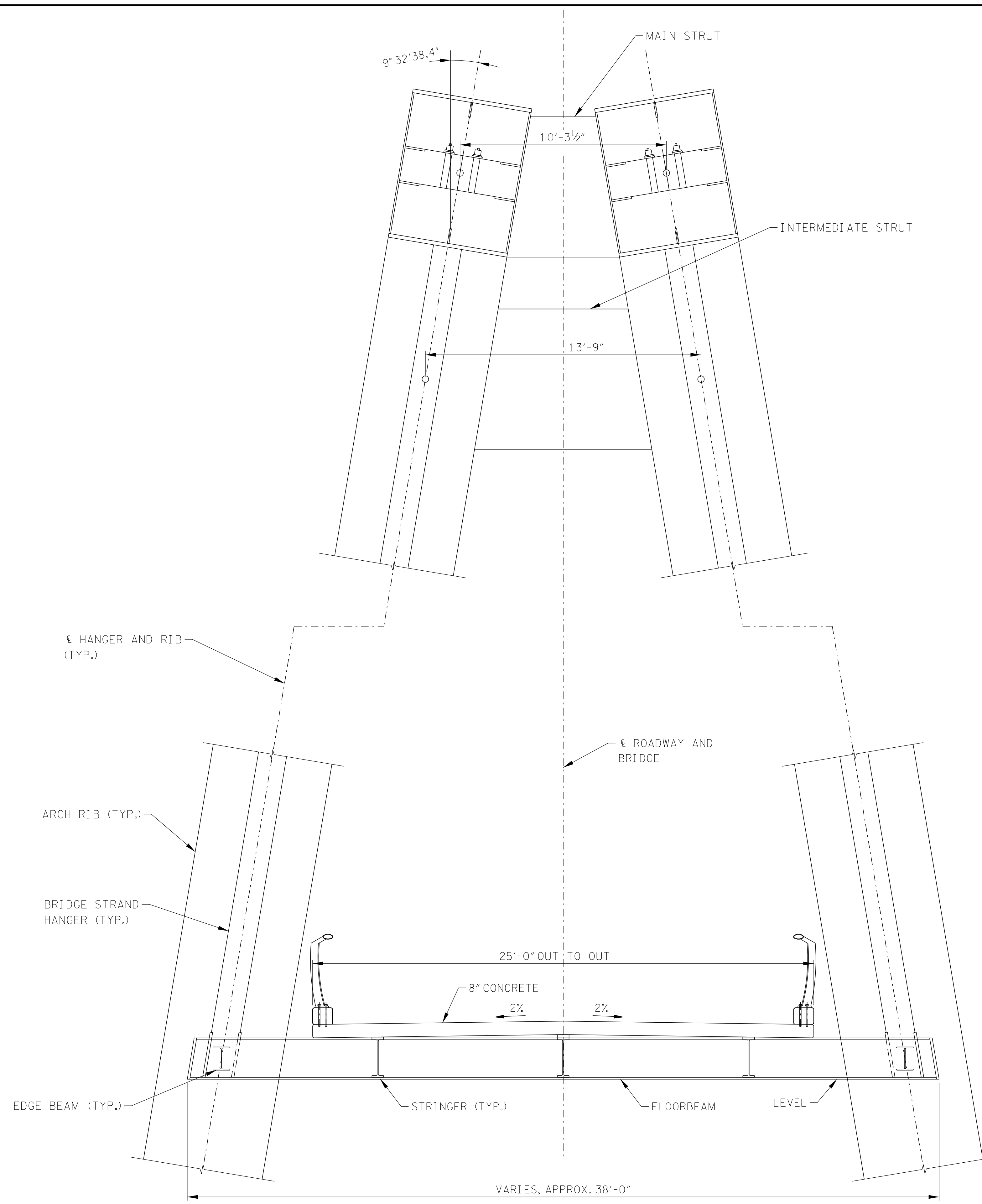

SECTION

SEALED BY

CITY OF KNOXVILLE
URBAN DESIGN & DEVELOPMENT / ENGINEERING
SOUTH WATERFRONT PEDESTRIAN BRIDGE OVER TENNESSEE RIVER
KNOX COUNTY
2025



PIN NO.: _____
 DESIGN BY: ARA DATE: FEB 2024
 DRAWN BY: DJC DATE: FEB 2024
 SUPERVISED BY: DEM DATE: FEB 2024
 CHECKED BY: _____ DATE: _____

2/6/2024 10:18:39 AM \\MMDC10\Projects_2\4733.01-Knoxville Pedestrian Bridge\CADD\Structural\4773.01-XX-Cross Section.dgn

CONST. NO.:

PROJECT NO.	YEAR	SHEET NO.
XXXXXX-MX-XXX	2025	4

REVISIONS

NO.	DATE	BY	BRIEF DESCRIPTION

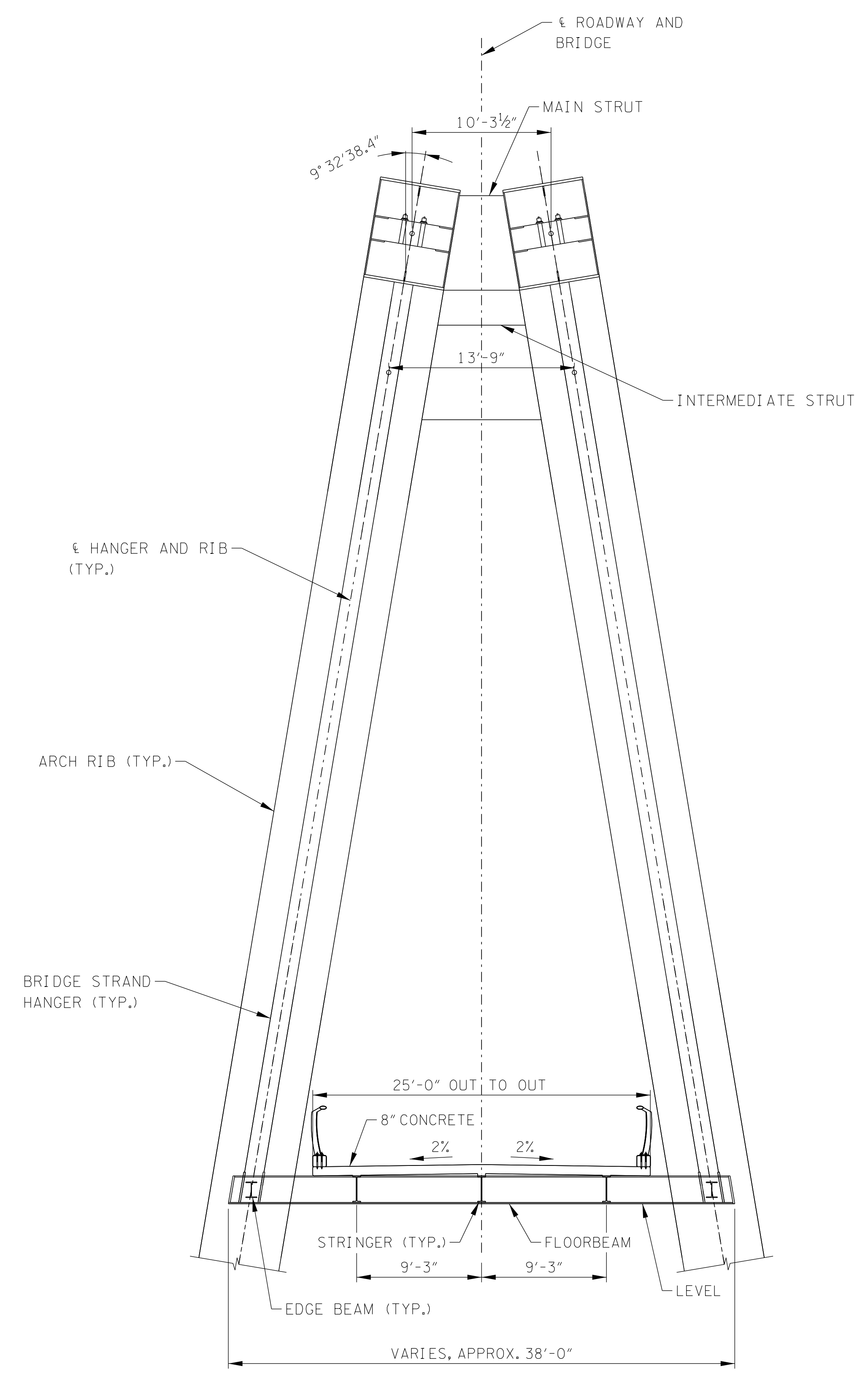

CAUTION!
PRELIMINARY
PLANS
SUBJECT TO
CHANGE

SEALED BY

CITY OF KNOXVILLE
URBAN DESIGN & DEVELOPMENT / ENGINEERING
SOUTH WATERFRONT PEDESTRIAN BRIDGE OVER TENNESSEE RIVER
KNOX COUNTY
2025



PIN NO.: _____
 DESIGN BY: ARA DATE: FEB 2024
 DRAWN BY: DJC DATE: FEB 2024
 SUPERVISED BY: DEM DATE: FEB 2024
 CHECKED BY: _____ DATE: _____

2/6/2024 10:18:41 AM \\MMDC10\Projects_2\4733.01-Knoxville Pedestrian Bridge\CADD\Structural\4773.01-XX-Cross Section-2.dgn

CONST. NO.:

PROJECT NO.	YEAR	SHEET NO.	
XXXXXX-MX-XXX	2025	7	
REVISIONS			
NO.	DATE	BY	BRIEF DESCRIPTION



**CAUTION!
PRELIMINARY
PLANS
SUBJECT TO
CHANGE**



SEALED BY

2/6/2024 10:18:41 AM \\MDC10\Projects_214733.01-Knoxville Pedestrian Bridge\CADD\Structural\4773.01-XX-Cross Section-2.dgn

PIN NO.:	_____	DATE: FEB 2024
DESIGN BY:	ARA	DATE: FEB 2024
DRAWN BY:	DJC	DATE: FEB 2024
SUPERVISED BY:	DEM	DATE: FEB 2024
CHECKED BY:	_____	DATE: _____

CITY OF KNOXVILLE
URBAN DESIGN & DEVELOPMENT / ENGINEERING
SOUTH WATERFRONT PEDESTRIAN BRIDGE OVER TENNESSEE RIVER
KNOX COUNTY
2025